

■ Absolute Maximum Ratings (Ta=25°C)

Parameter	Symbol	Rating	Unit
Input voltage	V _I	35 *1	V
		40 *2	V
Power dissipation	P _D	8 *3	W
Operating ambient temperature	T _{opr}	-20 to +80	°C
Storage temperature	T _{stg}	-55 to +150	°C

*1 AN78N04, AN78N05, AN78N06, AN78N07, AN78N08, AN78N09, AN78N10, AN78N12, AN78N15, AN78N18

*2 AN78N20, AN78N24

*3 Follow the derating curve. When T_j exceeds 150°C, the internal circuit cuts off the output.

■ Electrical Characteristics (Ta=25°C)

• AN78N04 (4V Type)

Parameter	Symbol	Condition	min	typ	max	Unit
Output voltage	V _O	T _j =25°C	3.84	4	4.16	V
Output voltage tolerance	V _O	V _I =6.5 to 20V, I _O =5 to 200mA	3.8	—	4.2	V
Line regulation	REG _{IN}	V _I =6.5 to 25V, T _j =25°C	—	9	40	mV
		V _I =7 to 20V, T _j =25°C	—	4	20	mV
Load regulation	REG _L	I _O =1 to 300mA, T _j =25°C	—	20	80	mV
		I _O =5 to 200mA, T _j =25°C	—	10	40	mV
Bias current	I _{bias}	T _j =25°C	—	2.8	5	mA
Input bias current fluctuation	ΔI _{bias (IN)}	V _I =6.5 to 25V, T _j =25°C	—	—	0.8	mA
Load bias current fluctuation	ΔI _{bias (L)}	I _O =1 to 300mA, T _j =25°C	—	—	0.5	mA
Output noise voltage	V _{no}	f=10Hz to 100kHz	—	38	—	μV
Ripple rejection ratio	RR	V _I =7 to 17V, I _O =50mA, f=120Hz	62	72	—	dB
Minimum input/output voltage difference	V _{DIF (min.)}	I _O =300mA, T _j =25°C	—	2	—	V
Output short circuit current	I _{O (Short)}	V _I =35V, T _j =25°C	—	300	—	mA
Peak output current	I _{O (Peak)}	T _j =25°C	—	500	—	mA
Output voltage temperature coefficient	ΔV _O /Ta	I _O =5mA, T _j =0 to 125°C	—	-0.3	—	mV/°C

Note 1) The specified condition T_j=25°C means that the test should be carried out with the test time so short (within 10ms) that the drift in characteristic value due to the rise in chip junction temperature can be ignored.

Note 2) When not specified, V_I=9V, I_O=100mA, C_I=0.33μF, C_O=0.1μF, T_j=0 to 125°C

■ Electrical Characteristics (Ta=25°C)

• AN78N05 (5V Type)

Parameter	Symbol	Condition	min	typ	max	Unit
Output voltage	V_O	$T_j=25^\circ\text{C}$	4.8	5	5.2	V
Output voltage tolerance	V_O	$V_I=7.5$ to 20V, $I_O=5$ to 200mA	4.75	—	5.25	V
Line regulation	REG_{IN}	$V_I=7.5$ to 25V, $T_j=25^\circ\text{C}$	—	10	50	mV
		$V_I=8$ to 20V, $T_j=25^\circ\text{C}$	—	5	25	mV
Load regulation	REG_{L}	$I_O=1$ to 300mA, $T_j=25^\circ\text{C}$	—	20	100	mV
		$I_O=5$ to 200mA, $T_j=25^\circ\text{C}$	—	10	50	mV
Bias current	I_{bias}	$T_j=25^\circ\text{C}$	—	2.8	5	mA
Input bias current fluctuation	$\Delta I_{\text{bias (IN)}}$	$V_I=7.5$ to 25V, $T_j=25^\circ\text{C}$	—	—	0.8	mA
Load bias current fluctuation	$\Delta I_{\text{bias (L)}}$	$I_O=1$ to 300mA, $T_j=25^\circ\text{C}$	—	—	0.5	mA
Output noise voltage	V_{no}	$f=10\text{Hz}$ to 100kHz	—	40	—	μV
Ripple rejection ratio	RR	$V_I=8$ to 18V, $I_O=50\text{mA}$, $f=120\text{Hz}$	62	72	—	dB
Minimum input/output voltage difference	$V_{\text{DIF (min.)}}$	$I_O=300\text{mA}$, $T_j=25^\circ\text{C}$	—	2	—	V
Output short circuit current	$I_{\text{O (Short)}}$	$V_I=35\text{V}$, $T_j=25^\circ\text{C}$	—	300	—	mA
Peak output current	$I_{\text{O (Peak)}}$	$T_j=25^\circ\text{C}$	—	500	—	mA
Output voltage temperature coefficient	$\Delta V_O/T_a$	$I_O=5\text{mA}$, $T_j=0$ to 125°C	—	-0.3	—	$\text{mV}/^\circ\text{C}$

Note 1) The specified condition $T_j=25^\circ\text{C}$ means that the test should be carried out with the test time so short (within 10ms) that the drift in characteristic value due to the rise in chip junction temperature can be ignored.

Note 2) When not specified, $V_I=10\text{V}$, $I_O=100\text{mA}$, $C_I=0.33\mu\text{F}$, $C_O=0.1\mu\text{F}$, $T_j=0$ to 125°C

• AN78N06 (6V Type)

Parameter	Symbol	Condition	min	typ	max	Unit
Output voltage	V_O	$T_j=25^\circ\text{C}$	5.75	6	6.25	V
Output voltage tolerance	V_O	$V_I=8.5$ to 20V, $I_O=5$ to 200mA	5.7	—	6.3	V
Line regulation	REG_{IN}	$V_I=8.5$ to 25V, $T_j=25^\circ\text{C}$	—	11	60	mV
		$V_I=9$ to 20V, $T_j=25^\circ\text{C}$	—	6	30	mV
Load regulation	REG_{L}	$I_O=1$ to 300mA, $T_j=25^\circ\text{C}$	—	20	120	mV
		$I_O=5$ to 200mA, $T_j=25^\circ\text{C}$	—	10	60	mV
Bias current	I_{bias}	$T_j=25^\circ\text{C}$	—	2.8	5	mA
Input bias current fluctuation	$\Delta I_{\text{bias (IN)}}$	$V_I=8.5$ to 25V, $T_j=25^\circ\text{C}$	—	—	0.8	mA
Load bias current fluctuation	$\Delta I_{\text{bias (L)}}$	$I_O=1$ to 300mA, $T_j=25^\circ\text{C}$	—	—	0.5	mA
Output noise voltage	V_{no}	$f=10\text{Hz}$ to 100kHz	—	45	—	μV
Ripple rejection ratio	RR	$V_I=9$ to 19V, $I_O=50\text{mA}$, $f=120\text{Hz}$	59	70	—	dB
Minimum input/output voltage difference	$V_{\text{DIF (min.)}}$	$I_O=300\text{mA}$, $T_j=25^\circ\text{C}$	—	2	—	V
Output short circuit current	$I_{\text{O (Short)}}$	$V_I=35\text{V}$, $T_j=25^\circ\text{C}$	—	300	—	mA
Peak output current	$I_{\text{O (Peak)}}$	$T_j=25^\circ\text{C}$	—	500	—	mA
Output voltage temperature coefficient	$\Delta V_O/T_a$	$I_O=5\text{mA}$, $T_j=0$ to 125°C	—	-0.4	—	$\text{mV}/^\circ\text{C}$

Note 1) The specified condition $T_j=25^\circ\text{C}$ means that the test should be carried out with the test time so short (within 10ms) that the drift in characteristic value due to the rise in chip junction temperature can be ignored.

Note 2) When not specified, $V_I=11\text{V}$, $I_O=100\text{mA}$, $C_I=0.33\mu\text{F}$, $C_O=0.1\mu\text{F}$, $T_j=0$ to 125°C

■ Electrical Characteristics (Ta=25°C)

• AN78N07(7V Type)

Parameter	Symbol	Condition	min	typ	max	Unit
Output voltage	V_O	$T_j=25^\circ\text{C}$	6.7	7	7.3	V
Output voltage tolerance	V_O	$V_I=9.5$ to 20V, $I_O=5$ to 200mA	6.65	—	7.35	V
Line regulation	REG_{IN}	$V_I=9.5$ to 25V, $T_j=25^\circ\text{C}$	—	12	70	mV
		$V_I=10$ to 20V, $T_j=25^\circ\text{C}$	—	7	35	mV
Load regulation	REG_{L}	$I_O=1$ to 300mA, $T_j=25^\circ\text{C}$	—	20	140	mV
		$I_O=5$ to 200mA, $T_j=25^\circ\text{C}$	—	10	70	mV
Bias current	I_{bias}	$T_j=25^\circ\text{C}$	—	2.8	5	mA
Input bias current fluctuation	$\Delta I_{\text{bias (IN)}}$	$V_I=9.5$ to 25V, $T_j=25^\circ\text{C}$	—	—	0.8	mA
Load bias current fluctuation	$\Delta I_{\text{bias (L)}}$	$I_O=1$ to 300mA, $T_j=25^\circ\text{C}$	—	—	0.5	mA
Output noise voltage	V_{no}	$f=10\text{Hz}$ to 100kHz	—	50	—	μV
Ripple rejection ratio	RR	$V_I=10$ to 20V, $I_O=50\text{mA}$, $f=120\text{Hz}$	57	69	—	dB
Minimum input/output voltage difference	$V_{\text{DIF (min.)}}$	$I_O=300\text{mA}$, $T_j=25^\circ\text{C}$	—	2	—	V
Output short circuit current	$I_{\text{O (Short)}}$	$V_I=35\text{V}$, $T_j=25^\circ\text{C}$	—	300	—	mA
Peak output current	$I_{\text{O (Peak)}}$	$T_j=25^\circ\text{C}$	—	500	—	mA
Output voltage temperature coefficient	$\Delta V_O/T_a$	$I_O=5\text{mA}$, $T_j=0$ to 125°C	—	-0.4	—	$\text{mV}/^\circ\text{C}$

Note 1) The specified condition $T_j=25^\circ\text{C}$ means that the test should be carried out with the test time so short (within 10ms) that the drift in characteristic value due to the rise in chip junction temperature can be ignored.

Note 2) When not specified, $V_I=12\text{V}$, $I_O=100\text{mA}$, $C_I=0.33\mu\text{F}$, $C_O=0.1\mu\text{F}$, $T_j=0$ to 125°C

• AN78N08 (8V Type)

Parameter	Symbol	Condition	min	typ	max	Unit
Output voltage	V_O	$T_j=25^\circ\text{C}$	7.7	8	8.3	V
Output voltage tolerance	V_O	$V_I=10.5$ to 23V, $I_O=5$ to 200mA	7.6	—	8.4	V
Line regulation	REG_{IN}	$V_I=10.5$ to 25V, $T_j=25^\circ\text{C}$	—	13	80	mV
		$V_I=12$ to 23V, $T_j=25^\circ\text{C}$	—	8	40	mV
Load regulation	REG_{L}	$I_O=1$ to 300mA, $T_j=25^\circ\text{C}$	—	25	160	mV
		$I_O=5$ to 200mA, $T_j=25^\circ\text{C}$	—	10	80	mV
Bias current	I_{bias}	$T_j=25^\circ\text{C}$	—	2.8	5	mA
Input bias current fluctuation	$\Delta I_{\text{bias (IN)}}$	$V_I=10.5$ to 25V, $T_j=25^\circ\text{C}$	—	—	0.8	mA
Load bias current fluctuation	$\Delta I_{\text{bias (L)}}$	$I_O=1$ to 300mA, $T_j=25^\circ\text{C}$	—	—	0.5	mA
Output noise voltage	V_{no}	$f=10\text{Hz}$ to 100kHz	—	55	—	μV
Ripple rejection ratio	RR	$V_I=11$ to 21V, $I_O=50\text{mA}$, $f=120\text{Hz}$	56	69	—	dB
Minimum input/output voltage difference	$V_{\text{DIF (min.)}}$	$I_O=300\text{mA}$, $T_j=25^\circ\text{C}$	—	2	—	V
Output short circuit current	$I_{\text{O (Short)}}$	$V_I=35\text{V}$, $T_j=25^\circ\text{C}$	—	300	—	mA
Peak output current	$I_{\text{O (Peak)}}$	$T_j=25^\circ\text{C}$	—	500	—	mA
Output voltage temperature coefficient	$\Delta V_O/T_a$	$I_O=5\text{mA}$, $T_j=0$ to 125°C	—	-0.4	—	$\text{mV}/^\circ\text{C}$

Note 1) The specified condition $T_j=25^\circ\text{C}$ means that the test should be carried out with the test time so short (within 10ms) that the drift in characteristic value due to the rise in chip junction temperature can be ignored.

Note 2) When not specified, $V_I=14\text{V}$, $I_O=100\text{mA}$, $C_I=0.33\mu\text{F}$, $C_O=0.1\mu\text{F}$, $T_j=0$ to 125°C

■ Electrical Characteristics (Ta=25°C)

• AN78N09 (9V Type)

Parameter	Symbol	Condition	min	typ	max	Unit
Output voltage	V_O	$T_j=25^\circ\text{C}$	8.65	9	9.35	V
Output voltage tolerance	V_O	$V_I=11.5$ to 24V, $I_O=5$ to 200mA	8.55	—	9.45	V
Line regulation	REG_{IN}	$V_I=11.5$ to 25V, $T_j=25^\circ\text{C}$	—	14	90	mV
		$V_I=13$ to 24V, $T_j=25^\circ\text{C}$	—	9	45	mV
Load regulation	REG_L	$I_O=1$ to 300mA, $T_j=25^\circ\text{C}$	—	25	180	mV
		$I_O=5$ to 200mA, $T_j=25^\circ\text{C}$	—	10	90	mV
Bias current	I_{bias}	$T_j=25^\circ\text{C}$	—	2.8	5	mA
Input bias current fluctuation	$\Delta I_{bias(IN)}$	$V_I=11.5$ to 25V, $T_j=25^\circ\text{C}$	—	—	0.8	mA
Load bias current fluctuation	$\Delta I_{bias(L)}$	$I_O=1$ to 300mA, $T_j=25^\circ\text{C}$	—	—	0.5	mA
Output noise voltage	V_{no}	f=10Hz to 100kHz	—	60	—	μV
Ripple rejection ratio	RR	$V_I=12$ to 22V, $I_O=50$ mA, f=120Hz	56	68	—	dB
Minimum input/output voltage difference	$V_{DIF(min.)}$	$I_O=300$ mA, $T_j=25^\circ\text{C}$	—	2	—	V
Output short circuit current	$I_{O(Short)}$	$V_I=35$ V, $T_j=25^\circ\text{C}$	—	300	—	mA
Peak output current	$I_{O(Peak)}$	$T_j=25^\circ\text{C}$	—	500	—	mA
Output voltage temperature coefficient	$\Delta V_O/T_a$	$I_O=5$ mA, $T_j=0$ to 125°C	—	-0.5	—	mV/°C

Note 1) The specified condition $T_j=25^\circ\text{C}$ means that the test should be carried out with the test time so short (within 10ms) that the drift in characteristic value due to the rise in chip junction temperature can be ignored.

Note 2) When not specified, $V_I=15$ V, $I_O=100$ mA, $C_I=0.33\mu\text{F}$, $C_O=0.1\mu\text{F}$, $T_j=0$ to 125°C

• AN78N10 (10V Type)

Parameter	Symbol	Condition	min	typ	max	Unit
Output voltage	V_O	$T_j=25^\circ\text{C}$	9.6	10	10.4	V
Output voltage tolerance	V_O	$V_I=12.5$ to 25V, $I_O=5$ to 200mA	9.5	—	10.5	V
Line regulation	REG_{IN}	$V_I=12.5$ to 30V, $T_j=25^\circ\text{C}$	—	15	100	mV
		$V_I=13$ to 25V, $T_j=25^\circ\text{C}$	—	10	50	mV
Load regulation	REG_L	$I_O=1$ to 300mA, $T_j=25^\circ\text{C}$	—	25	200	mV
		$I_O=5$ to 200mA, $T_j=25^\circ\text{C}$	—	10	100	mV
Bias current	I_{bias}	$T_j=25^\circ\text{C}$	—	2.8	5	mA
Input bias current fluctuation	$\Delta I_{bias(IN)}$	$V_I=12.5$ to 30V, $T_j=25^\circ\text{C}$	—	—	0.8	mA
Load bias current fluctuation	$\Delta I_{bias(L)}$	$I_O=1$ to 300mA, $T_j=25^\circ\text{C}$	—	—	0.5	mA
Output noise voltage	V_{no}	f=10Hz to 100kHz	—	70	—	μV
Ripple rejection ratio	RR	$V_I=13$ to 23V, $I_O=50$ mA, f=120Hz	56	68	—	dB
Minimum input/output voltage difference	$V_{DIF(min.)}$	$I_O=300$ mA, $T_j=25^\circ\text{C}$	—	2	—	V
Output short circuit current	$I_{O(Short)}$	$V_I=35$ V, $T_j=25^\circ\text{C}$	—	300	—	mA
Peak output current	$I_{O(Peak)}$	$T_j=25^\circ\text{C}$	—	500	—	mA
Output voltage temperature coefficient	$\Delta V_O/T_a$	$I_O=5$ mA, $T_j=0$ to 125°C	—	-0.5	—	mV/°C

Note 1) The specified condition $T_j=25^\circ\text{C}$ means that the test should be carried out with the test time so short (within 10ms) that the drift in characteristic value due to the rise in chip junction temperature can be ignored.

Note 2) When not specified, $V_I=16$ V, $I_O=100$ mA, $C_I=0.33\mu\text{F}$, $C_O=0.1\mu\text{F}$, $T_j=0$ to 125°C

■ Electrical Characteristics (Ta=25°C)

• AN78N12 (12V Type)

Parameter	Symbol	Condition	min	typ	max	Unit
Output voltage	V_O	$T_j=25^\circ\text{C}$	11.5	12	12.5	V
Output voltage tolerance	V_O	$V_I=14.5$ to 27V , $I_O=5$ to 200mA	11.4	—	12.6	V
Line regulation	REG_{IN}	$V_I=14.5$ to 30V , $T_j=25^\circ\text{C}$	—	15	100	mV
		$V_I=16$ to 27V , $T_j=25^\circ\text{C}$	—	10	50	mV
Load regulation	REG_{L}	$I_O=1$ to 300mA , $T_j=25^\circ\text{C}$	—	25	240	mV
		$I_O=5$ to 200mA , $T_j=25^\circ\text{C}$	—	10	120	mV
Bias current	I_{bias}	$T_j=25^\circ\text{C}$	—	2.8	5	mA
Input bias current fluctuation	$\Delta I_{\text{bias (IN)}}$	$V_I=14.5$ to 30V , $T_j=25^\circ\text{C}$	—	—	0.8	mA
Load bias current fluctuation	$\Delta I_{\text{bias (L)}}$	$I_O=1$ to 300mA , $T_j=25^\circ\text{C}$	—	—	0.5	mA
Output noise voltage	V_{no}	$f=10\text{Hz}$ to 100kHz	—	80	—	μV
Ripple rejection ratio	RR	$V_I=15$ to 25V , $I_O=50\text{mA}$, $f=120\text{Hz}$	55	67	—	dB
Minimum input/output voltage difference	$V_{\text{DIF (min.)}}$	$I_O=300\text{mA}$, $T_j=25^\circ\text{C}$	—	2	—	V
Output short circuit current	$I_{\text{O (Short)}}$	$V_I=35\text{V}$, $T_j=25^\circ\text{C}$	—	300	—	mA
Peak output current	$I_{\text{O (Peak)}}$	$T_j=25^\circ\text{C}$	—	500	—	mA
Output voltage temperature coefficient	$\Delta V_O/T_a$	$I_O=5\text{mA}$, $T_j=0$ to 125°C	—	-0.6	—	$\text{mV}/^\circ\text{C}$

Note 1) The specified condition $T_j=25^\circ\text{C}$ means that the test should be carried out with the test time so short (within 10ms) that the drift in characteristic value due to the rise in chip junction temperature can be ignored.

Note 2) When not specified, $V_I=19\text{V}$, $I_O=100\text{mA}$, $C_I=0.33\mu\text{F}$, $C_O=0.1\mu\text{F}$, $T_j=0$ to 125°C

• AN78N15 (15V Type)

Parameter	Symbol	Condition	min	typ	max	Unit
Output voltage	V_O	$T_j=25^\circ\text{C}$	14.4	15	15.6	V
Output voltage tolerance	V_O	$V_I=17.5$ to 20V , $I_O=5$ to 200mA	14.25	—	15.75	V
Line regulation	REG_{IN}	$V_I=17.5$ to 25V , $T_j=25^\circ\text{C}$	—	16	100	mV
		$V_I=20$ to 30V , $T_j=25^\circ\text{C}$	—	11	50	mV
Load regulation	REG_{L}	$I_O=1$ to 300mA , $T_j=25^\circ\text{C}$	—	25	300	mV
		$I_O=5$ to 200mA , $T_j=25^\circ\text{C}$	—	10	150	mV
Bias current	I_{bias}	$T_j=25^\circ\text{C}$	—	2.8	5	mA
Input bias current fluctuation	$\Delta I_{\text{bias (IN)}}$	$V_I=17.5$ to 30V , $T_j=25^\circ\text{C}$	—	—	0.8	mA
Load bias current fluctuation	$\Delta I_{\text{bias (L)}}$	$I_O=1$ to 300mA , $T_j=25^\circ\text{C}$	—	—	0.5	mA
Output noise voltage	V_{no}	$f=10\text{Hz}$ to 100kHz	—	80	—	μV
Ripple rejection ratio	RR	$V_I=18.5$ to 28.5V , $I_O=50\text{mA}$, $f=120\text{Hz}$	54	66	—	dB
Minimum input/output voltage difference	$V_{\text{DIF (min.)}}$	$I_O=300\text{mA}$, $T_j=25^\circ\text{C}$	—	2	—	V
Output short circuit current	$I_{\text{O (Short)}}$	$V_I=35\text{V}$, $T_j=25^\circ\text{C}$	—	300	—	mA
Peak output current	$I_{\text{O (Peak)}}$	$T_j=25^\circ\text{C}$	—	500	—	mA
Output voltage temperature coefficient	$\Delta V_O/T_a$	$I_O=5\text{mA}$, $T_j=0$ to 125°C	—	-0.8	—	$\text{mV}/^\circ\text{C}$

Note 1) The specified condition $T_j=25^\circ\text{C}$ means that the test should be carried out with the test time so short (within 10ms) that the drift in characteristic value due to the rise in chip junction temperature can be ignored.

Note 2) When not specified, $V_I=23\text{V}$, $I_O=100\text{mA}$, $C_I=0.33\mu\text{F}$, $C_O=0.1\mu\text{F}$, $T_j=0$ to 125°C

■ Electrical Characteristics (Ta=25°C)

• AN78N18 (18V Type)

Parameter	Symbol	Condition	min	typ	max	Unit
Output voltage	V_O	$T_j=25^\circ\text{C}$	17.3	18	18.7	V
Output voltage tolerance	V_O	$V_I=21$ to 33V, $I_O=5$ to 200mA	17.1	—	18.9	V
Line regulation	REG _{IN}	$V_I=21$ to 33V, $T_j=25^\circ\text{C}$	—	18	100	mV
		$V_I=22$ to 33V, $T_j=25^\circ\text{C}$	—	13	50	mV
Load regulation	REG _L	$I_O=1$ to 300mA, $T_j=25^\circ\text{C}$	—	30	360	mV
		$I_O=5$ to 200mA, $T_j=25^\circ\text{C}$	—	10	180	mV
Bias current	I_{bias}	$T_j=25^\circ\text{C}$	—	2.8	5	mA
Input bias current fluctuation	$\Delta I_{\text{bias (IN)}}$	$V_I=21$ to 33V, $T_j=25^\circ\text{C}$	—	—	0.8	mA
Load bias current fluctuation	$\Delta I_{\text{bias (L)}}$	$I_O=1$ to 300mA, $T_j=25^\circ\text{C}$	—	—	0.5	mA
Output noise voltage	V_{no}	$f=10\text{Hz}$ to 100kHz	—	90	—	μV
Ripple rejection ratio	RR	$V_I=22$ to 32V, $I_O=50\text{mA}$, $f=120\text{Hz}$	53	65	—	dB
Minimum input/output voltage difference	$V_{\text{DIF (min.)}}$	$I_O=300\text{mA}$, $T_j=25^\circ\text{C}$	—	2	—	V
Output short circuit current	$I_{\text{O (Short)}}$	$V_I=35\text{V}$, $T_j=25^\circ\text{C}$	—	300	—	mA
Peak output current	$I_{\text{O (Peak)}}$	$T_j=25^\circ\text{C}$	—	500	—	mA
Output voltage temperature coefficient	$\Delta V_O/T_a$	$I_O=5\text{mA}$, $T_j=0$ to 125°C	—	-1.0	—	mV/°C

Note 1) The specified condition $T_j=25^\circ\text{C}$ means that the test should be carried out with the test time so short (within 10ms) that the drift in characteristic value due to the rise in chip junction temperature can be ignored.

Note 2) When not specified, $V_I=27\text{V}$, $I_O=100\text{mA}$, $C_1=0.33\mu\text{F}$, $C_0=0.1\mu\text{F}$, $T_j=0$ to 125°C

• AN78N20 (20V Type)

Parameter	Symbol	Condition	min	typ	max	Unit
Output voltage	V_O	$T_j=25^\circ\text{C}$	19.2	20	20.8	V
Output voltage tolerance	V_O	$V_I=23$ to 35V, $I_O=5$ to 200mA	19.0	—	21	V
Line regulation	REG _{IN}	$V_I=23$ to 35V, $T_j=25^\circ\text{C}$	—	19	100	mV
		$V_I=24$ to 35V, $T_j=25^\circ\text{C}$	—	14	50	mV
Load regulation	REG _L	$I_O=1$ to 300mA, $T_j=25^\circ\text{C}$	—	30	400	mV
		$I_O=5$ to 200mA, $T_j=25^\circ\text{C}$	—	10	200	mV
Bias current	I_{bias}	$T_j=25^\circ\text{C}$	—	2.8	5	mA
Input bias current fluctuation	$\Delta I_{\text{bias (IN)}}$	$V_I=23$ to 35V, $T_j=25^\circ\text{C}$	—	—	0.8	mA
Load bias current fluctuation	$\Delta I_{\text{bias (L)}}$	$I_O=1$ to 300mA, $T_j=25^\circ\text{C}$	—	—	0.5	mA
Output noise voltage	V_{no}	$f=10\text{Hz}$ to 100kHz	—	100	—	μV
Ripple rejection ratio	RR	$V_I=24$ to 34V, $I_O=50\text{mA}$, $f=120\text{Hz}$	52	64	—	dB
Minimum input/output voltage difference	$V_{\text{DIF (min.)}}$	$I_O=300\text{mA}$, $T_j=25^\circ\text{C}$	—	2	—	V
Output short circuit current	$I_{\text{O (Short)}}$	$V_I=35\text{V}$, $T_j=25^\circ\text{C}$	—	300	—	mA
Peak output current	$I_{\text{O (Peak)}}$	$T_j=25^\circ\text{C}$	—	500	—	mA
Output voltage temperature coefficient	$\Delta V_O/T_a$	$I_O=5\text{mA}$, $T_j=0$ to 125°C	—	-1.2	—	mV/°C

Note 1) The specified condition $T_j=25^\circ\text{C}$ means that the test should be carried out with the test time so short (within 10ms) that the drift in characteristic value due to the rise in chip junction temperature can be ignored.

Note 2) When not specified, $V_I=29\text{V}$, $I_O=100\text{mA}$, $C_1=0.33\mu\text{F}$, $C_0=0.1\mu\text{F}$, $T_j=0$ to 125°C

■ Electrical Characteristics (Ta=25°C)

• AN78N24 (24V Type)

Parameter	Symbol	Condition	min	typ	max	Unit
Output voltage	V_O	$T_j=25^\circ\text{C}$	23	24	25	V
Output voltage tolerance	V_O	$V_I=27$ to 38V , $I_O=5$ to 200mA	22.8	—	25.2	V
Line regulation	REG_{IN}	$V_I=27$ to 38V , $T_j=25^\circ\text{C}$	—	20	100	mV
		$V_I=28$ to 38V , $T_j=25^\circ\text{C}$	—	15	50	mV
Load regulation	REG_{L}	$I_O=1$ to 300mA , $T_j=25^\circ\text{C}$	—	30	480	mV
		$I_O=5$ to 200mA , $T_j=25^\circ\text{C}$	—	10	240	mV
Bias current	I_{bias}	$T_j=25^\circ\text{C}$	—	2.8	5	mA
Input bias current fluctuation	$\Delta I_{\text{bias (IN)}}$	$V_I=27$ to 38V , $T_j=25^\circ\text{C}$	—	—	0.8	mA
Load bias current fluctuation	$\Delta I_{\text{bias (L)}}$	$I_O=1$ to 300mA , $T_j=25^\circ\text{C}$	—	—	0.5	mA
Output noise voltage	V_{no}	$f=10\text{Hz}$ to 100kHz	—	110	—	μV
Ripple rejection ratio	RR	$V_I=28$ to 38V , $I_O=50\text{mA}$, $f=120\text{Hz}$	50	63	—	dB
Minimum input/output voltage difference	$V_{\text{DIF (min.)}}$	$I_O=300\text{mA}$, $T_j=25^\circ\text{C}$	—	2	—	V
Output short circuit current	$I_{\text{O (Short)}}$	$V_I=35\text{V}$, $T_j=25^\circ\text{C}$	—	300	—	mA
Peak output current	$I_{\text{O (Peak)}}$	$T_j=25^\circ\text{C}$	—	500	—	mA
Output voltage temperature coefficient	$\Delta V_O/T_a$	$I_O=5\text{mA}$, $T_j=0$ to 125°C	—	-1.5	—	$\text{mV}/^\circ\text{C}$

Note 1) The specified condition $T_j=25^\circ\text{C}$ means that the test should be carried out with the test time so short (within 10ms) that the drift in characteristic value due to the rise in chip junction temperature can be ignored.

Note 2) When not specified, $V_I=33\text{V}$, $I_O=100\text{mA}$, $C_I=0.33\mu\text{F}$, $C_O=0.1\mu\text{F}$, $T_j=0$ to 125°C

■ Basic Regulator Circuit

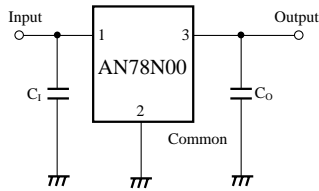

C_1 : is set when the input line is long.
 C_0 : improves the transient response.

■ Application Circuit

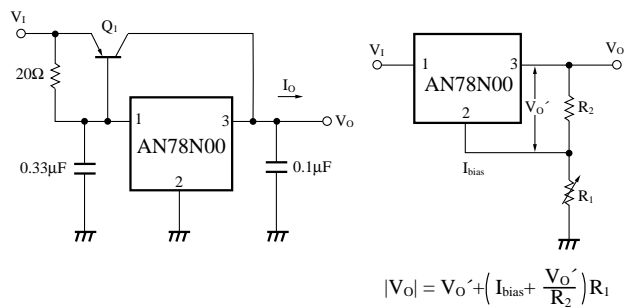

$$|V_O| = V_O' + \left(I_{\text{bias}} + \frac{V_O'}{R_2} \right) R_1$$

■ Characteristic Curve

