

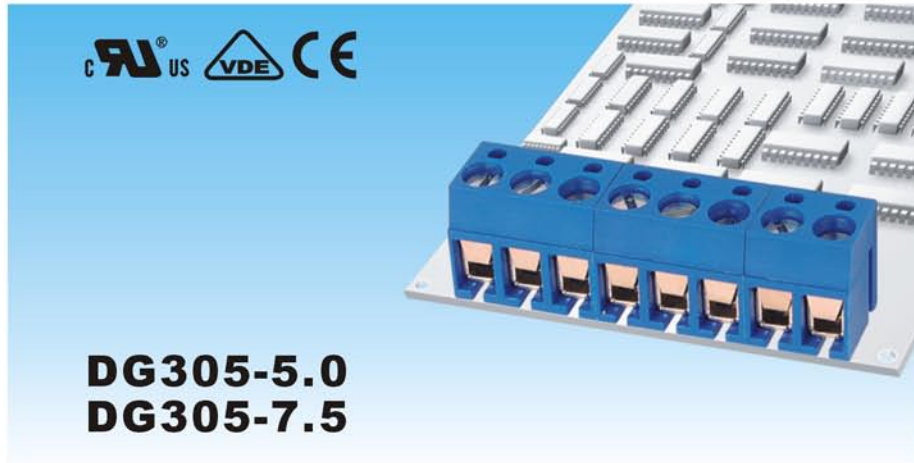

# DEGSON ELECTRONICS CO., LTD.

## Product Specification



Material	
Screws :	M3 steel Zinc plated
Wire guard:	Stainless steel
Pin header:	Brass, Tin plated
Housing :	PBT, UL94V-0
Electrical	
Rated voltage :	300V
Rated current :	15A
Contact resistance :	20mΩ
Insulation resistance :	5000MΩ /DC 1000V
Withstanding voltage:	AC2000V/1Min
Wire range :	22-14AWG 2.5mm <sup>2</sup>
Mechanical	
Temp. Range :	-30°C~+120°C
Torque :	0.5Nm(4.5lb.in)
Strip length :	4.5-5mm

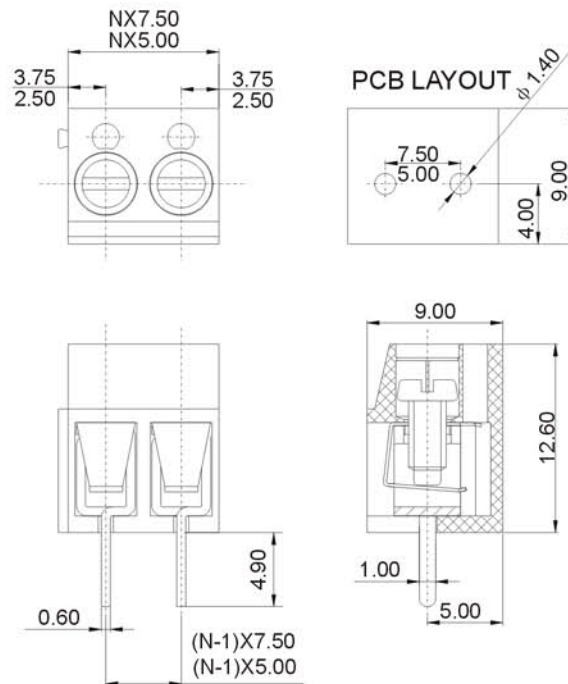

### HOW TO ORDER:

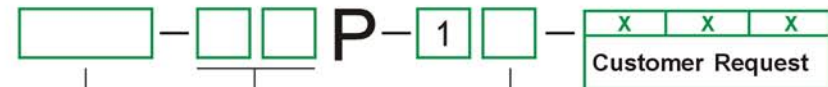

Series No. No of Pole

Color

1 Gray	4 Green	7 Trans- parent
2 Blue	5 Orange	8 Yellow
3 Black	6 Red	9 White

	<b>DEGSON ELECTRONICS CO., LTD.</b>
	NAME <b>DG305-5.0</b> <b>DG305-7.5</b>