

# POWERTIP TECH. CORP.

DISPLAY DEVICES FOR BETTER ELECTRONIC DESIGN

## Specification For Approval

### 【產品規格書】

Customer : \_\_\_\_\_

Model Type : LCD Module

Sample Code : PG320240WRF-HNNHP2

Mass Production Code : \_\_\_\_\_

Edition : 0

Customer Sign	Sales Sign	Approved By	Prepared By

# CONTENTS

## 1. SPECIFICATIONS

- 1.1 Features
- 1.2 Mechanical Specifications
- 1.3 Absolute Maximum Ratings
- 1.4 DC Electrical Characteristics
- 1.5 Optical Characteristics
- 1.6 Backlight Characteristics

## 2. MODULE STRUCTURE

- 2.1 Driver ICs
- 2.2 Interface Pin Description
- 2.3 Timing Characteristics

## 3. Appendix

- 3.1 Counter drawing



## 1. SPECIFICATIONS

### 1.1 Features

- Full dot-matrix structure with 320 dots \*240 dots
- 1/240 Duty, 1/14 bias
- FSTN LCD, positive, Black & White display
- Transflective LCD, 6 o'clock viewing angle
- 4 bits parallel data input
- With LED backlight

### 1.2 Mechanical Specifications

- Outline dimension : 92.0mm(W)\*71.3mm(H)\*7.9mm max.(D)
- Viewing area : 78.78mm \*59.58mm
- Active area : 76.78mm \*57.58mm
- Dot size : 0.22mm \*0.22mm
- Dot pitch : 0.24mm \*0.24mm
- Interface connector : 16-pin flat ribbon connector with 1mm pitch
- Driver ICs : TCP type

### 1.3 Absolute Maximum Ratings

Item	Symbol	Conditions	Min.	Max.	Unit
Power supply Voltage	V <sub>DD</sub>	V <sub>SS</sub> =0V	-0.3	7	V
	V <sub>EE</sub>		-0.3	32	V
Input voltage	V <sub>IN</sub>		-0.3	V <sub>DD</sub> +0.3	V
Operating temperature	T <sub>opr</sub>		-20	70	°C
Storage temperature	T <sub>stg</sub>		-30	80	°C
Humidity	H <sub>D</sub>		20	70	%RH

### 1.4 DC Electrical Characteristics

V<sub>DD</sub>=+5V±10% , V<sub>SS</sub>=0V, T<sub>a</sub>=25°C

Item	Symbol	Condition	Min.	Typ.	Max.	Unit
Logic Supply voltage	V <sub>DD</sub>	-	2.5	5.0	5.5	V
“H” input voltage	V <sub>IH</sub>	-	0.8 V <sub>DD</sub>	-	-	V
“L” input voltage	V <sub>IL</sub>	-	-	-	0.2 V <sub>DD</sub>	V
“H” output voltage	V <sub>OH</sub>	I <sub>OH</sub> =-0.4mA	V <sub>DD</sub> -0.4	-	-	V
“L” output voltage	V <sub>OL</sub>	I <sub>OL</sub> =+0.4mA	-	-	+0.4	V
Supply current	I <sub>DD</sub>	V <sub>DD</sub> =5V	-	1.4	1.6	mA



LCD driving voltage	VLCD	Ta=25°C	-	21.6	21.8	V
---------------------	------	---------	---	------	------	---

### 1.5 Optical Characteristics

Vopr=24.8V, 1/240 duty, 1/17 bias, Ta=25°C

Item	Symbol	Conditions	Min.	Typ.	Max	Reference
Viewing angle	$\theta$	$C \geq 2.0, \varnothing = 0^\circ$	-25°	-	25°	Notes 1 & 2
Contrast	C	$\theta = 0^\circ, \varnothing = 0^\circ$	-	2.8	-	Note 3
Response time(rise)	tr	$\theta = 0^\circ, \varnothing = 0^\circ$	-	150ms	169ms	Note 4
Response time(fall)	tf	$\theta = 0^\circ, \varnothing = 0^\circ$	-	240ms	249ms	Note 4

Note 1: Definition of angles  $\theta$  and  $\varnothing$

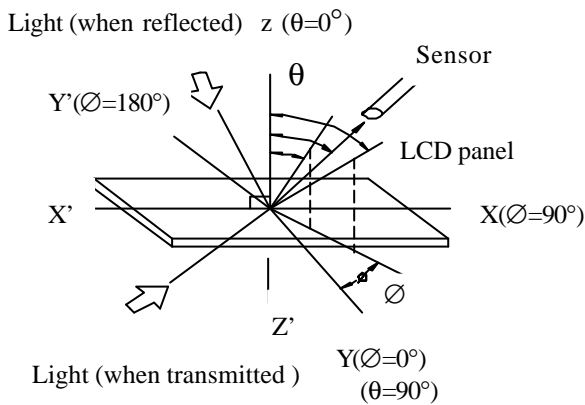

Note 2: Definition of viewing angles  $\theta_1$  and  $\theta_2$

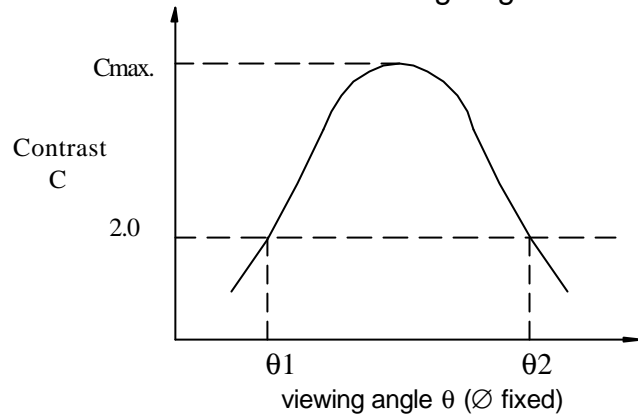

Note : Optimum viewing angle with the naked eye and viewing angle  $\theta$  at Cmax. Above are not always the same

Note 3: Definition of contrast C

$$C = \frac{\text{Brightness (reflection) of unselected dot (B2)}}{\text{Brightness (reflection) of selected dot (B1)}}$$

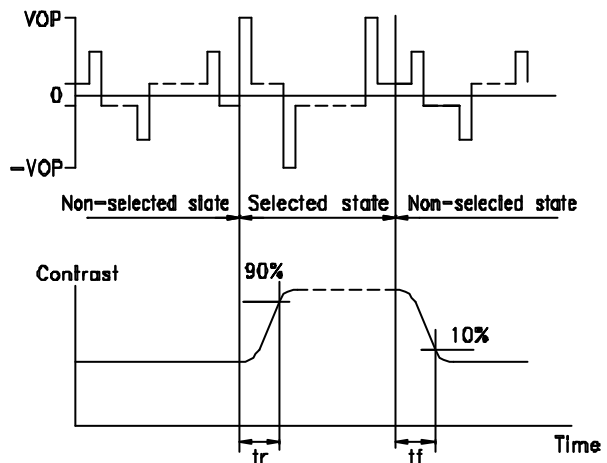
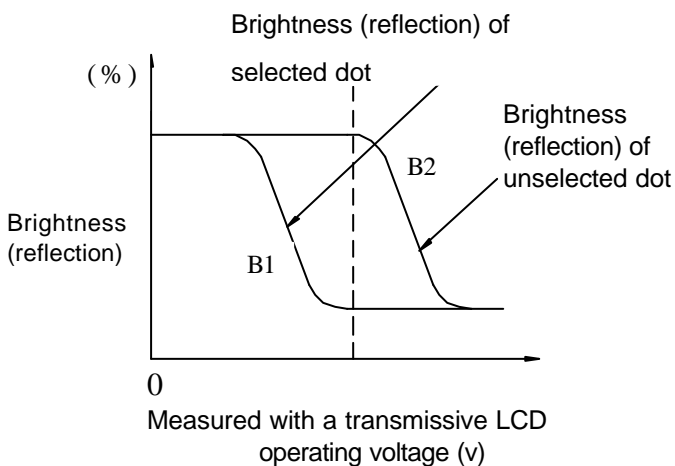

Note:

panel which is displayed 1 cm<sup>2</sup>

V<sub>OPR</sub> : Operating voltage      f<sub>FRM</sub> : Frame frequency  
 t<sub>ON</sub> : Response time (rise)    t<sub>OFF</sub> : Response time (fall)



**POWERTIP TECHNOLOGY CORPORATION**

DISPLAY DEVICES FOR BETTER ELECTRONIC DESIGN

## 1.6 Backlight Characteristic

The LCD Module is built-in an White LED backlight.

Absolute Maximum Ratings: (Ta=25°C)

Item	Symbol	Ratings	Unit
Peak forward current	IF	120	mA
Reverse voltage	VR	5	V
Power dissipation	Po	0.48	W
Operating temperature	Topr	-20 to +70	°C
Storage temperature	Tstg	-40 to +80	°C
Soldering temperature: 3 sec.		260	°C

Electrical/Optical specifications:

ITEM	Symbol	Condition	Min.	Typ	Max.	Unit
Forward Voltage	Vf	If= 60mA	-	3.3	4.0	V
Reverse Current	Ir	Vr= 5V	-	-	0.2	mA
Luminous Intensity ( with LCD )	Iv	If= 80mA	5.0	8.0	-	cd/m <sup>2</sup>
Color Coordinate	X	If= 60mA		0.29		
	Y			0.30		
Color	White					

## 2.MODULE STRUCTURE

The PG320240-H includes a common driver, two segment drivers, a bias voltage generation circuit, and LED backlight.

### 2.1 Driver ICS

Segment driver : IST3021F3\*2 or ST8016F3\*2 or LH1565F3\*2

Common driver : IST3022F4\*1 or ST8024F4\*1 or LH1562F4\*1

Block diagram



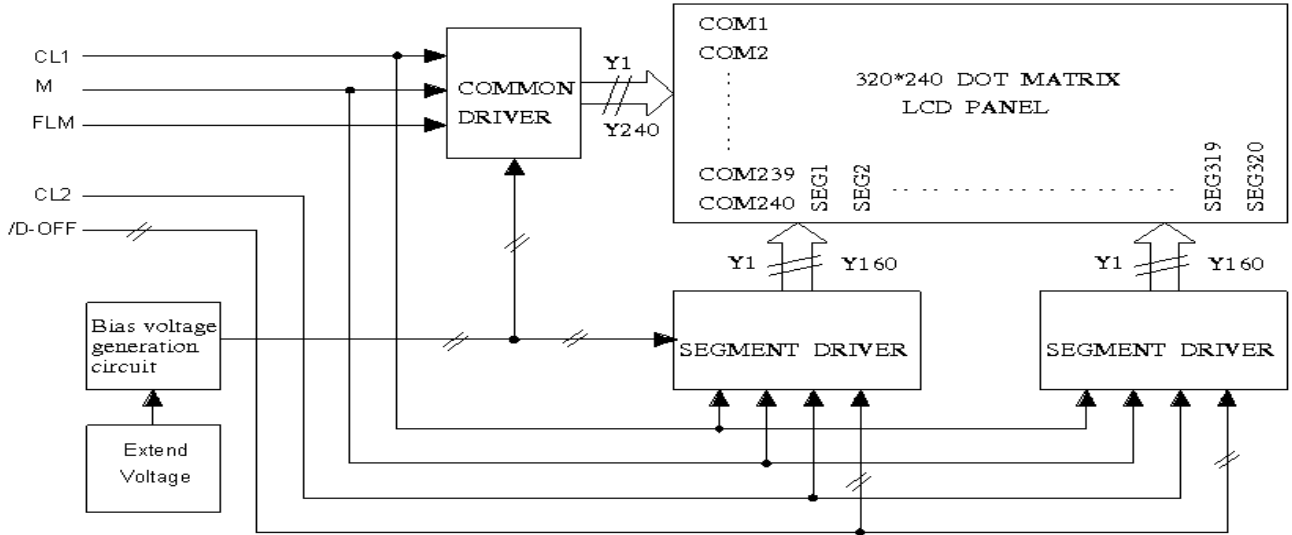

## 2.2 Interface Pin Description

PIN	SIGNAL NAME	DESCRIPTION
1	FLM	Indicates the beginning of each display cycle.
2	M	AC signal input for LC driving waveform
3	CL1	Bi-directional shift register shift clock pulse input pin.
4	CL2	Clock input pin for taking display data
5	/D-OFF	Control input pin for output deselect level
6	DB0	Display data input pin
7	DB1	Display data input pin
8	DB2	Display data input pin
9	DB3	Display data input pin
10	V <sub>DD</sub>	Logic system power supply pin
11	V <sub>SS</sub>	Ground pin
12	V <sub>EE</sub>	LCD Operator Voltage
13	V <sub>SS</sub>	Ground pin
14	NC	No connection
15	A	Power supply for LED Backlight (+)
16	K	Power supply for LED Backlight (-)

**Note :** FLM Recommended 55Hz ~ 75Hz

M Recommended 200Hz ~ 400Hz

Contrast Adjust

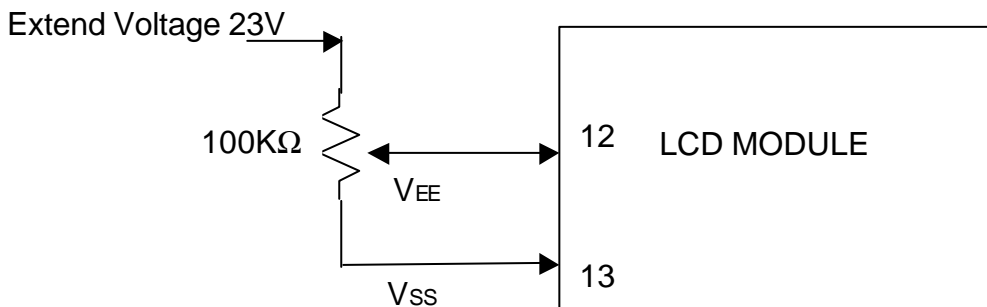

### 2.3 Timing Characteristics

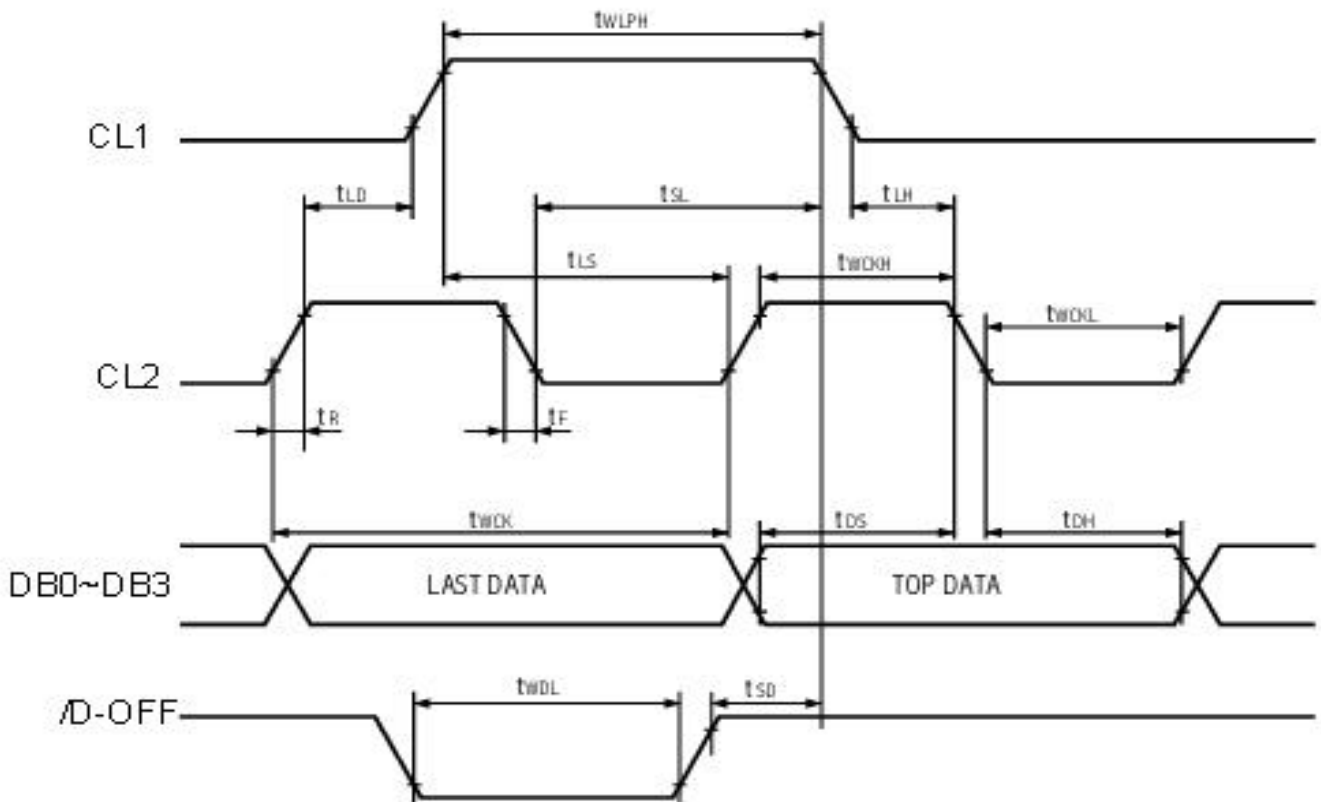

$V_{SS}=0V, V_{DD}=2.5V \text{ to } 5.5V, T_a=25$

Parameter	Symol	Condition	Min.	Typ.	Max.	Unit
Shift clock period	$t_{WCLK}$	$t_r, t_f$ 11 ns	125			ns
Shift clock "H" pulse width	$t_{WCLKH}$		51			ns
Shift clock "L" pulse width	$t_{WCLKL}$		51			ns
Data setup time	$t_{DS}$		30			ns
Data hold time	$t_{DH}$		40			ns
Latch pulse "H" pulse width	$t_{WLPH}$		51			ns
Shift clock rise to Latch pulse rise time	$t_{LD}$		0			ns
Shift clock fall to Latch pulse fall time	$t_{SL}$		51			ns
Latch pulse rise to Shift clock rise time	$t_{LS}$		51			ns
Latch pulse fall to Shift clock fall time	$t_{LH}$		51			ns
Input signal rise time	$t_r$				50	ns



Input signal fall time	$t_f$				50	ns
/Dispoff removal time	$t_{SD}$		100			ns
/Dispoff "L" pulse width	$t_{WDL}$		1.2			us
Output delay time (1)	$t_{pd1}, t_{pd2}$	CL=15 pF			1.2	us
Output delay time (2)	$t_{pd3}$	CL=15 pF			1.2	us

#### 4 Bits Panel Timing





